



Designed to be connected to any brand of conventional fire detection systems. Internal 470-ohm resistance allow ease of installation. It is suitable for flush and surface mounting. An optional transparent protective cover can be installed. It is easily resettable via special key.

### GENERAL FEATURES

- Resettable Type
- NC/NO Selection
- Includes 470 Ohm Resistance, does not Require Additional Connection
- Transparent Protection Cover can be Installed. Cover can be Sealed
- Suitable for Flush and Surface Mounting
- Compatible With all Conventional Fire and Theft Alarm Systems

- TFB-3165W, Emergency Call Point – WHITE
- TFB-3165B, Emergency Stop Call Point - BLUE
- TFB-3165Y, Manual Release Button – YELLOW
- TFB-3165G, Emergency Exit Door Release Button – GREEN
- TFB-3165O, - ORANGE

The cover is made of robust poly-carbon transparent material. It is used to prevent accidental button activation.

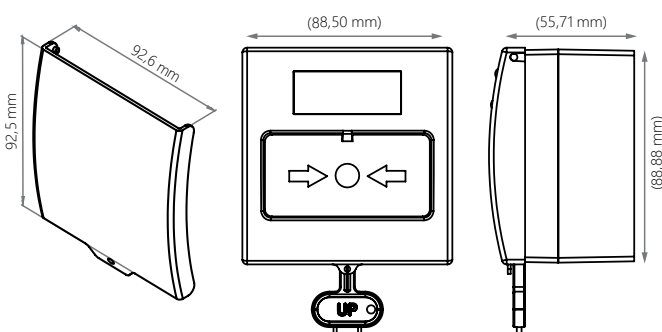

Technical Specifications	TFB-3165X
Operating Type	A Type Manual
Resettable	Yes
Relay	NC / NO / 470R
Power	5-30 VDC
Dimensions (mm)	165gr.
Weight	86x55x88mm
Color Codes	RAL 9010 White RAL 5002 BLUE RAL 1006 YELLOW RAL 6016 GREEN RAL2011 ORANGE
Type of Fragile Element	Resettable Polycarbonate
Operating Temperature	-10°C ~ 60°C
Humidity	≤93% RH at +40°C
Protection Class	IP30